

Sales Code: AK305

Description: Rigid Riser Kit For Bath Shower Mixer

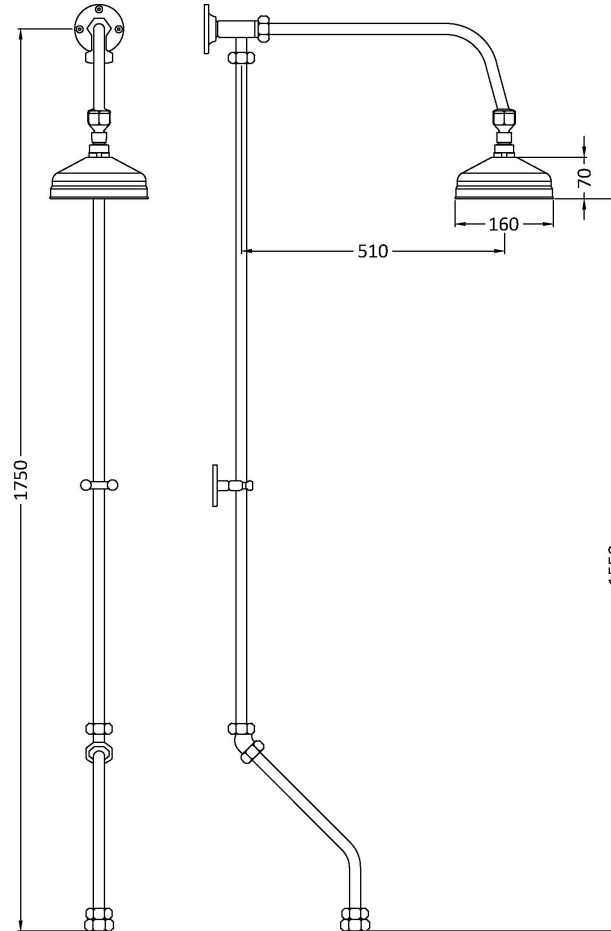

Product Dimensions

Length (mm):	
Width (mm):	70
Height (mm):	1750
Depth (mm):	590
Nett Weight (kg):	2.6

Packaging Dimensions

Length (mm):	1520
Width (mm):	170
Height (mm):	
Gross Weight (kg):	2.6

Packaging Data

Box Colour:	White Cardboard Box
Box Qty:	1
Label Size:	100 x 50
Label Colour:	White Label
Label Qty:	1

Outer Box Dimensions (If Applicable)

Length (mm):	
Width (mm):	
Height (mm):	
Depth (mm):	
Gross Weight (kg):	10
Barcode:	5055146101253

Product Details

Country of Origin:	China
Fitting Instruction:	No
Product Material:	Brass
Mount Type:	Wall
Outlet Elbow Supplied:	Not Applicable
Easy Clean:	Not Applicable
Head Included:	Yes
Handset Included:	No
Body Jets Included:	Not Applicable
No of Body Jets:	Not Applicable
Operating Pressure (bar):	
Valve/Cartridge Type:	Not Applicable
Flow Rates (L/min):	0.1 bar: N/A 0.5 bar: N/A 1 bar: N/A 2 bar: N/A 3 bar: N/A
TMV2 Approved:	No Approval No: N/A
TMV3 Approved:	No Approval No: N/A
WRAS Approved:	No Approval No: N/A
Head Function:	Single
Handset Function:	Not Applicable
Body Jet Info:	Not Applicable
Pipe Size:	22 mm (3/4" Bsp)
Pipe Centres:	N/A
Colour/Finish:	Chrome
Hose Included:	Yes
No. of Outlets:	1