

Sales Code: AQ-SCK

Description: 1850mm Enclosure Screw Cover Kit Chrome

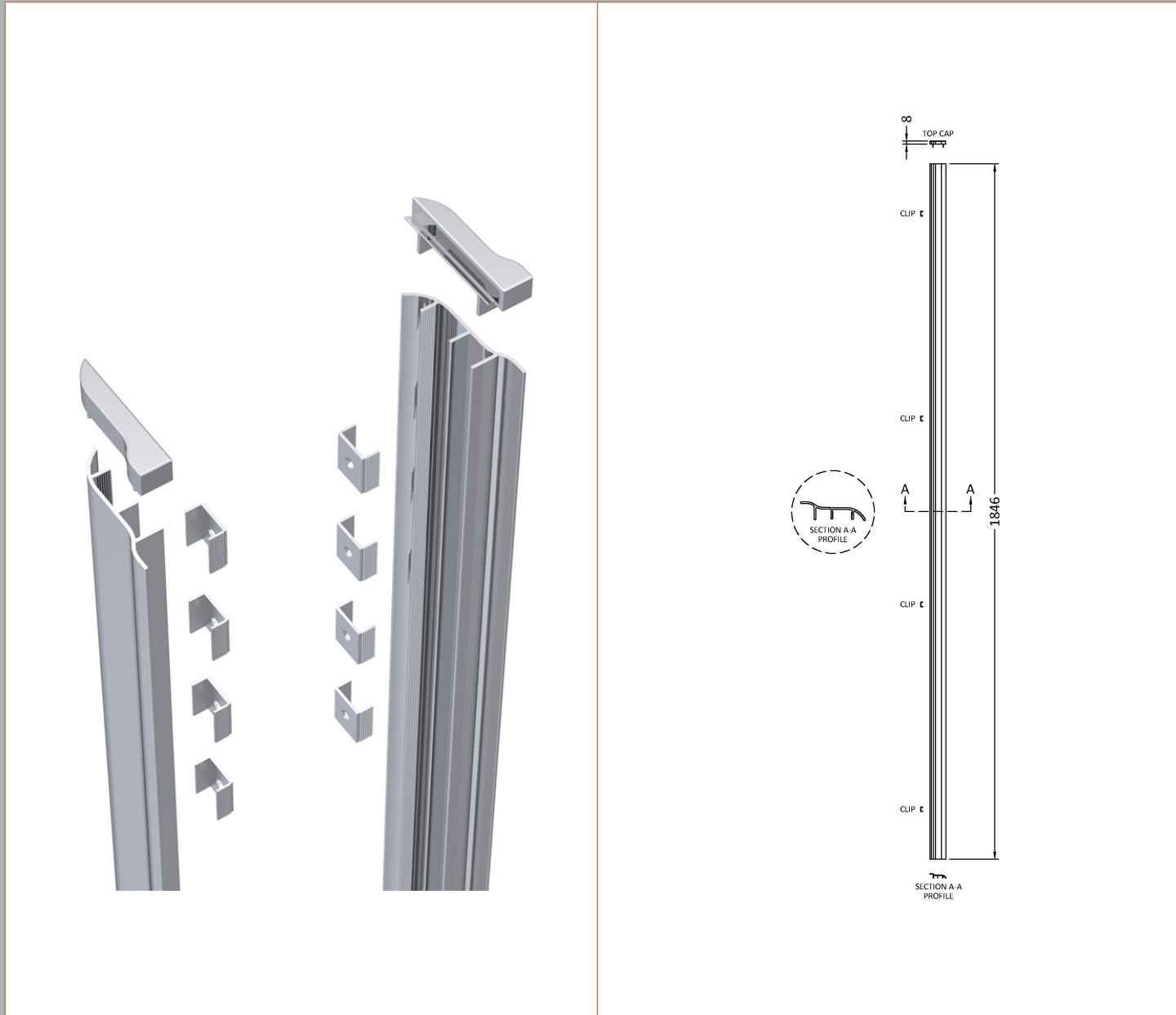

Product Dimensions

Height (mm):	1850
Width (mm):	43
Depth (mm):	12
Nett Weight (kg):	0.5

Packaging Dimensions

Height (mm):	1905
Width (mm):	52
Length (mm):	23
Gross Weight (kg):	0.55

Packaging Data

Box Colour:	Brown Cardboard Box
Box Qty:	1
Label Size:	100 x 50
Label Colour:	White Label
Label Qty:	1

Outer Box Dimensions (If Applicable)

Height (mm):	
Width (mm):	
Depth (mm):	
Length (mm):	
Gross Weight (kg):	
Barcode:	5055369076253

Product Details

Country of Origin:	China
Fitting Instruction:	No
CE & UKCA:	N/A
Profile Material:	Aluminium
Profile Finish:	Chrome
Adjustments (mm):	None
Entry Width (mm):	
Swing In Dim (mm):	
Swing Out Dim (mm):	
Radius (mm):	Not Applicable
Glass Thickness (mm):	
Easy Fit:	Yes
Easy Clean:	No
Handle Style:	Not Applicable
Handle Material:	Not Applicable
Enclosure Design:	Not Applicable
Wheel Type:	Not Applicable
Support Bar Included:	Support Bar Not Included
Extras:	None