

Sales Code: NCG340

Description: Freya Rimless Wall Hung Pan & Sc Seat

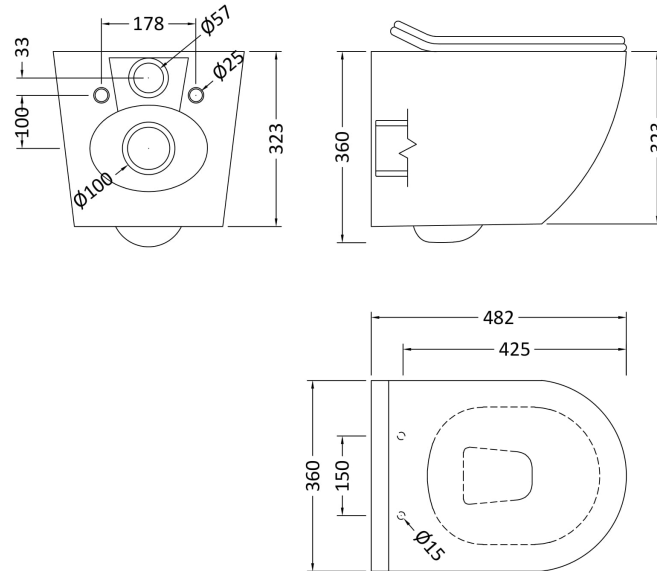
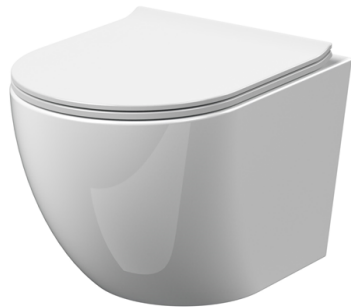

Product Dimensions

Height (mm):	323
Width (mm):	360
Depth (mm):	482
Nett Weight (kg):	32

Packaging Dimensions

Height (mm):	400
Width (mm):	430
Depth (mm):	422
Gross Weight (kg):	36

Packaging Data

Box Colour:	Brown Cardboard Box - Printed
Box Qty:	1
Label Size:	100 x 50
Label Colour:	Not Applicable
Label Qty:	2

Outer Box Dimensions (If Applicable)

Height (mm):	
Width (mm):	
Depth (mm):	
Gross Weight (kg):	
Barcode:	5056462623221

Product Details

Country of Origin:	China
Fitting Instruction:	No
Certification:	CE: WRAS: N/A WRAS No: N/A
Product Material:	Vitreous China
Fixing Supplied:	No

Pans/Bidets: Trap Style: Includes Seat: Yes

Seats: Seat Type: N/A Material: Urea
 Function: Soft Close Hinge Type: Top Fix, Quick Release
 Hinge Material: Stainless Steel

Cisterns: Operating Type: Not Applicable Fittings: Not Applicable
 Lever Type: Not Applicable

Basins: Tap Hole: Not Applicable Chain Stay Hole: Not Applicable
 Template: Not Applicable Waste Type Req: Not Applicable
 Overflow Inc: Not Applicable Overflow Cover: Not Applicable
 Inner Bowl Depth (mm): N/A