

Sales Code: NCS840

Description: Carlton Wall Hung Pan

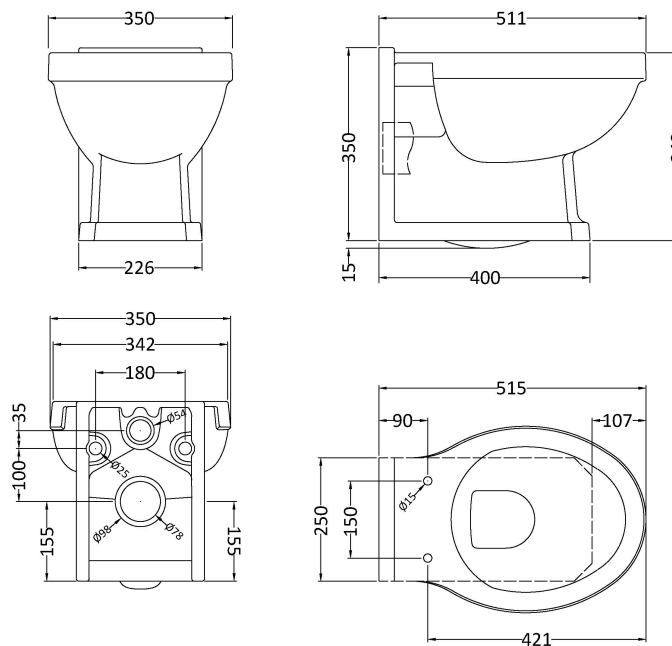

Product Dimensions

Height (mm):	365
Width (mm):	350
Depth (mm):	515
Nett Weight (kg):	21

Packaging Dimensions

Height (mm):	375
Width (mm):	360
Depth (mm):	525
Gross Weight (kg):	21.5

Packaging Data

Box Colour:	Brown Cardboard Box - Printed
Box Qty:	1
Label Size:	x
Label Colour:	Not Applicable
Label Qty:	

Outer Box Dimensions (If Applicable)

Height (mm):	
Width (mm):	
Depth (mm):	
Gross Weight (kg):	
Barcode:	5056462648170

Product Details

Country of Origin:	China
Fitting Instruction:	No
Certification:	CE: WRAS: N/A WRAS No: N/A
Product Material:	Vitreous China
Fixing Supplied:	No

Pans/Bidets: Trap Style: P Trap Includes Seat: No

Seats: Seat Type: N/A Material: Not Applicable
Function: Not Applicable Hinge Type: Not Applicable
Hinge Material: Not Applicable

Cisterns: Operating Type: Not Applicable Fittings: Not Applicable
Lever Type: N/A

Basins: Tap Hole: Not Applicable Chain Stay Hole: Not Applicable
Template: Not Applicable Waste Type Req: Not Applicable
Overflow Inc: Not Applicable Overflow Cover: Not Applicable
Inner Bowl Depth (mm): N/A