

Sales Code: QUEV51

Description: Quest Twin Valve Rectangular Plate

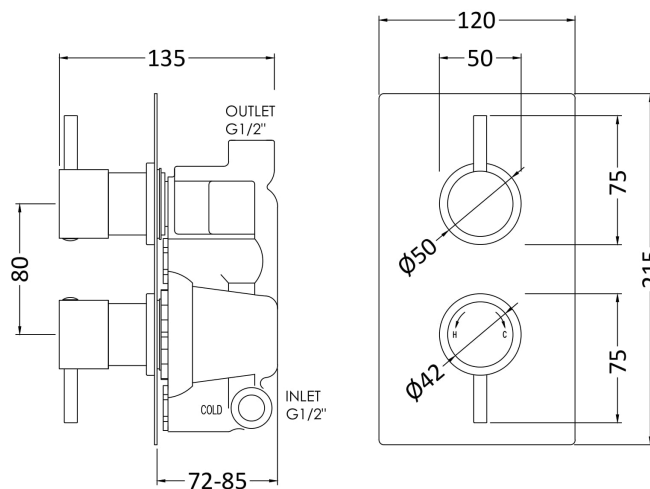

Product Dimensions

Length (mm):	
Width (mm):	120
Height (mm):	215
Depth (mm):	135
Nett Weight (kg):	2.71

Packaging Dimensions

Length (mm):	250
Width (mm):	240
Height (mm):	
Gross Weight (kg):	2.71

Packaging Data

Box Colour:	White Cardboard Box
Box Qty:	1
Label Size:	100 x 50
Label Colour:	White Label
Label Qty:	2

Outer Box Dimensions (If Applicable)

Length (mm):	
Width (mm):	500
Height (mm):	370
Depth (mm):	270
Gross Weight (kg):	16
Barcode:	5055146197218

Product Details

Country of Origin:	United Kingdom
Fitting Instruction:	No
Product Material:	Brass/ABS
Mount Type:	Wall, Recessed
Outlet Elbow Supplied:	No
Easy Clean:	Not Applicable
Head Included:	No
Handset Included:	No
Body Jets Included:	Not Applicable
No of Body Jets:	Not Applicable
Operating Pressure (bar):	0.1
Valve/Cartridge Type:	1/4 Turn Ceramic Disc
Flow Rates (L/min):	0.1 bar: 5.5 0.5 bar: 14 1 bar: 20 2 bar: 29 3 bar: 44
TMV2 Approved: Yes	Approval No: Bc 1875 00817
TMV3 Approved: Yes	Approval No: Nsf 1938 1217
WRAS Approved: Yes	Approval No: 1703023
Head Function:	Not Applicable
Handset Function:	Not Applicable
Body Jet Info:	Not Applicable
Pipe Size:	15 mm (1/2" Bsp)
Pipe Centres:	N/A
Colour/Finish:	Chrome
Hose Included:	Not Applicable
No. of Outlets:	1