

WRSF002 FITTING INSTRUCTION

UNPACK THE BOX AND ENSURE ALL COMPONENTS ARE PRESENT.

NO REFUNDS OR FITTING COSTS WILL BE GIVEN IF INCOMPLETE OR DAMAGED GOODS ARE FITTED.

TOOLS REQUIRED:
SILICONE GUN WITH SANITARY GRADE SEALANT - TAPE MEASURE - PENCIL - CROSS HEAD SCREW DRIVER - SPIRIT LEVEL - HACK SAW (FOR CUTTING ALUMINIUM).

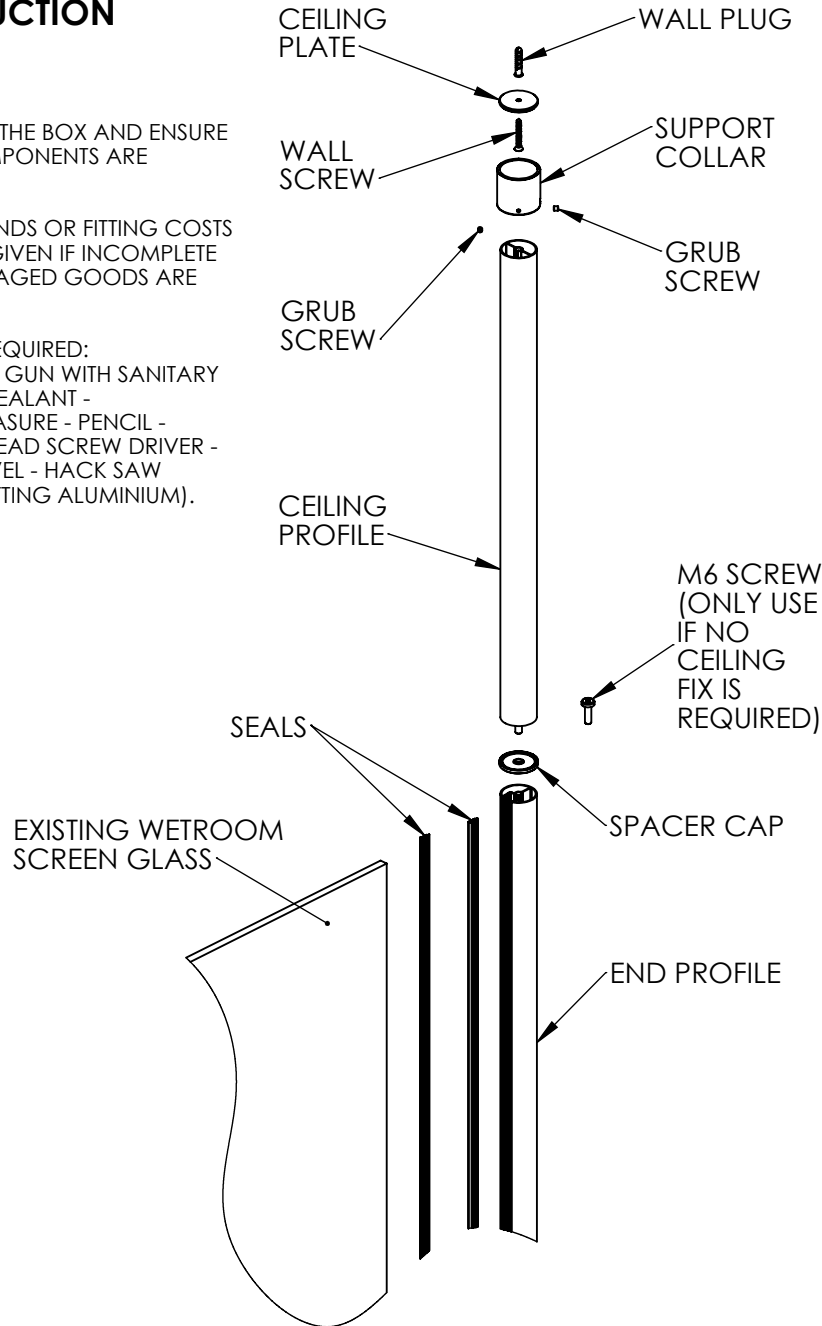

1.

MEASURE THE TOTAL HEIGHT OF GLASS AND CUT THE END PROFILE 1mm LONGER. USE MASKING TAPE WHEN CUTTING TO AVOID DAMAGING THE PROFILE. A FLAT AND SQUARE CUT IS ESSENTIAL. THIS CUT WILL BE AT THE BOTTOM OF THE GLASS.

CUT SEALS SAME LENGTH AS THE END PROFILE.

2.

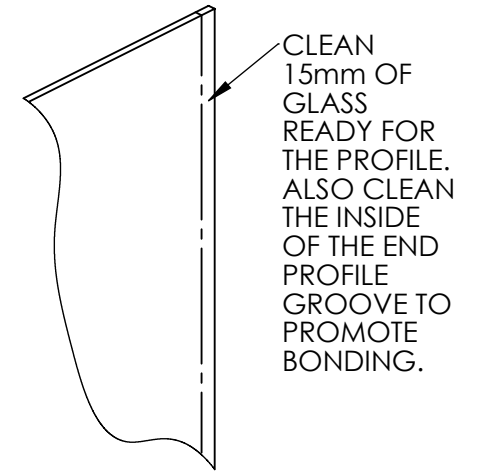

3.

SILICONE FLAT FACES

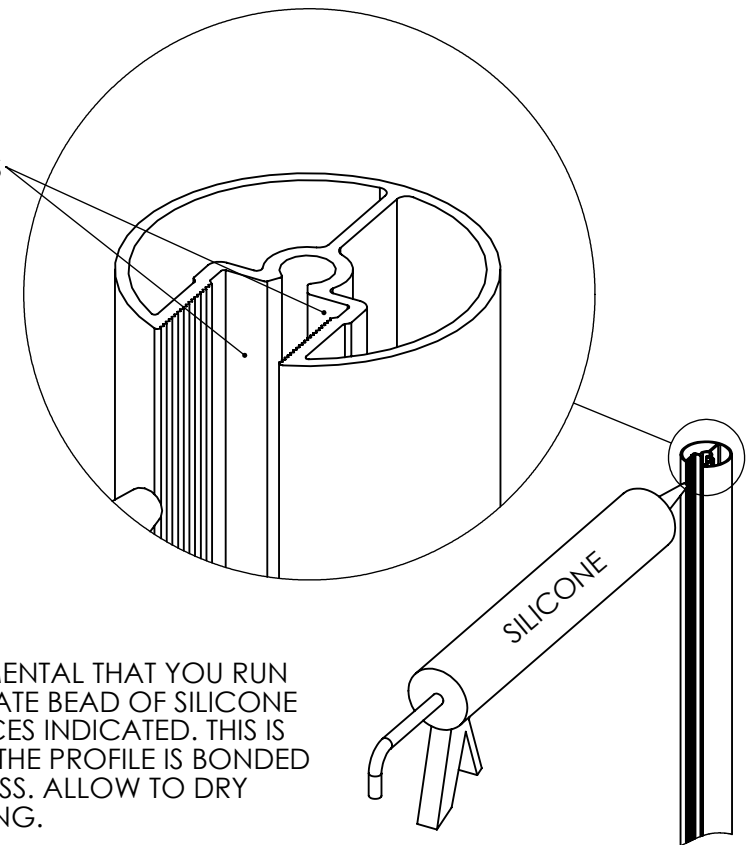

IT IS FUNDIMENTAL THAT YOU RUN AN ADEQUATE BEAD OF SILICONE ON THE FACES INDICATED. THIS IS TO ENSURE THE PROFILE IS BONDED TO THE GLASS. ALLOW TO DRY BEFORE USING.

4.

FIT END PROFILE ONTO GLASS.

INSERT TWO SEALS FOR 8mm GLASS AND USE ONE SEAL FOR 10mm GLASS, ON THE INSIDE OF THE SCREEN.

YOU CAN USE A WOODEN BLOCK TO AID FITTING OF THE SEALS, IF REQUIRED.

TAKE CARE NOT TO MARK THE PRODUCT.

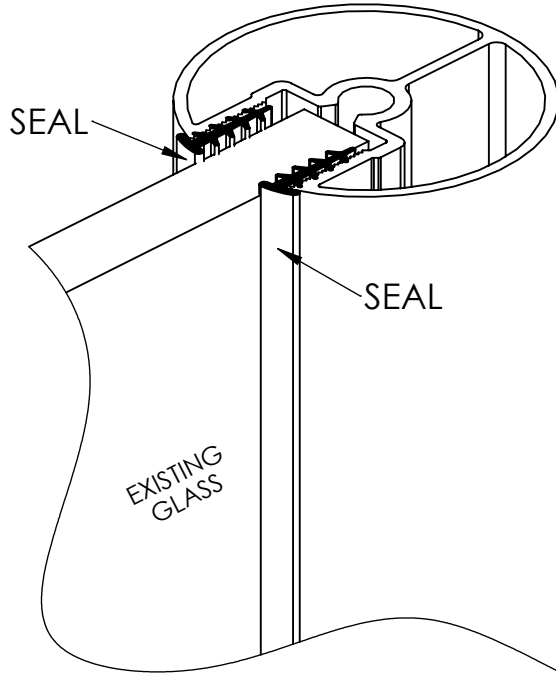

IF YOU'RE NOT USING THE CEILING FIX YOU CAN NOW FIT THE SPACER CAP AND M6 SCREW TO FINISH.

CEILING FIX

5.



FIT SPACER CAP. THEN MEASURE FROM CAP TO THE CEILING.

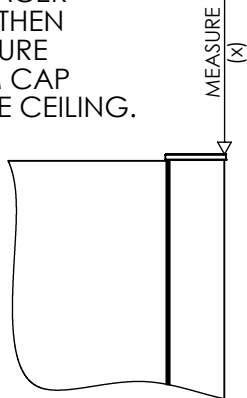

6.

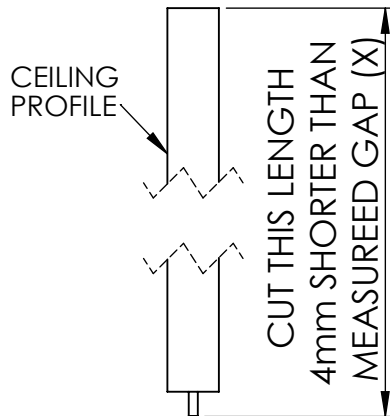

7.

SLIDE SUPPORT COLLAR ONTO CEILING PROFILE.

SCREW CEILING PROFILE ONTO END PROFILE.

ENSURE END PROFILE IS VERTICAL USING A SPIRIT LEVEL.

SLIDE SUPPORT COLLAR UP TO CEILING AND MARK AROUND WITH A PENCIL.

NOW REMOVE CEILING PROFILE.

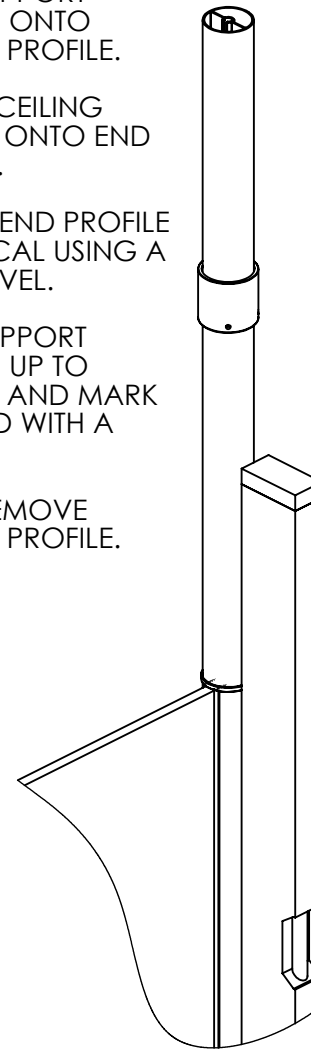

8. FIT CEILING PLATE TO CEILING USING SUITABLE FIXING FOR SUBSTRATE. (MASONRY FIXING SUPPLIED).

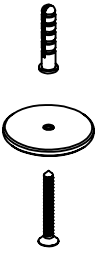

9. REPEAT STEP 7 THEN SCREW SUPPORT COLLAR ONTO CEILING PLATE.

10. FIT BOTH GRUB SCREWS INTO SUPPORT COLLAR.

WIPE OFF ANY EXCESS SILICONE.

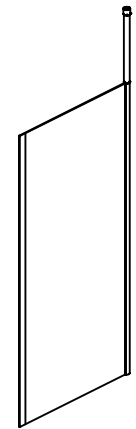

AFTERCARE: ENSURE YOU CLEAN YOUR PRODUCT USING A MILD DETERGENT DILUTED IN WATER. REMOVE ANY RESIDUE WITH A SOFT DAMP CLOTH.